

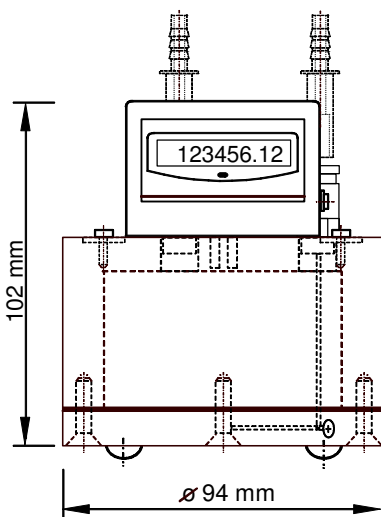

**Table of Contents**

|  | Page      |
|--|-----------|
| <b>1. Data Sheets.....</b>                                     | <b>3</b>  |
| <b>2. Initial Operation .....</b>                              | <b>9</b>  |
| 2.1. Handling after receipt.....                               | 9         |
| 2.2. Installation .....  | 9         |
| 2.3. Filling .....   | 10        |
| 2.3.1. PMMA Version (Transparent Casing) .....                 | 10        |
| 2.3.2. PVDF and PVC Version.....                               | 11        |
| 2.4. Connection of Tubing.....                                 | 12        |
| <b>3. Measurement .....</b>                                    | <b>12</b> |
| 3.1. Measurement principle.....                                | 12        |
| 3.2. Calibration / Measurement Error .....                     | 13        |
| 3.2.1. Static Correction of Manufacturing Tolerances .....     | 13        |
| 3.2.2. Dynamic Correction of the Measurement Error .....       | 13        |
| 3.3. Effect of Dead Space Volume .....                         | 13        |
| 3.4. Influence of Particles (Dirt & Dust) in the Gas Flow..... | 14        |
| 3.5. Effect of Temperature .....                               | 14        |
| 3.6. Effect of System Gas Pressure .....                       | 14        |
| 3.7. Effect of Water Vapour Partial Pressure.....              | 15        |
| 3.8. Temperature and Pressure Corrections .....                | 15        |
| 3.9. Special Features with Fermentation Tests .....            | 16        |
| <b>4. Counter unit.....</b>                                    | <b>17</b> |
| 4.1. Display.....  | 17        |
| 4.2. Reset Button .....  | 17        |
| 4.3. Signal Output .....                                       | 17        |
| 4.3.1. Reed Contact .....                                      | 17        |
| 4.3.2. Output Socket.....                                      | 18        |
| <b>5. Maintenance.....</b>                                     | <b>18</b> |
| 5.1. Checking the Packing Liquid Level .....                   | 18        |
| 5.2. Exchange of Packing Liquid.....                           | 19        |
| 5.3. Cleaning the Micro Capillary Tube .....                   | 19        |
| 5.4. Counter Unit Battery Exchange.....                        | 19        |
| 5.5. Disassembly / Exchange of the Measurement Cell .....      | 20        |
| 5.6. Long-term Storage.....                                    | 20        |

<sup>1</sup> Registered trademark. The MilliGascounter was developed at the University of Applied Science Hamburg under the leadership of Prof. Dr. Paul Scherer

**1. Data Sheets**



Front View

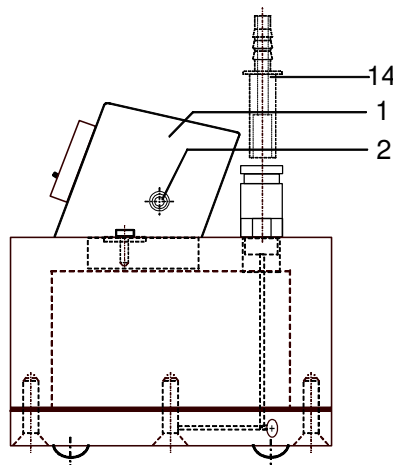

Side View

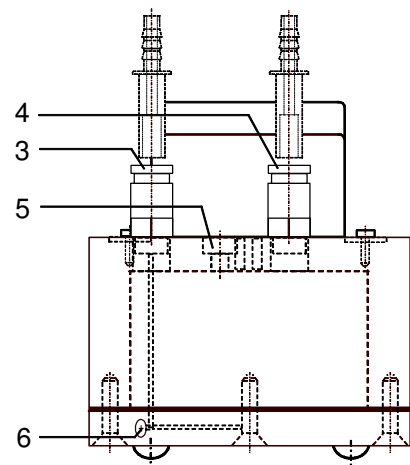

Rear View

- |  |                |                                  |
|--|----------------|----------------------------------|
| (1) Counter unit with LCD display                | (3) Gas Inlet  | (5) Air-vent screw for filling   |
| (2) Signal Output (reed contact)                 | (4) Gas Outlet | (6) Inspection screw gas channel |
| (14) Tube adaptors for flexible connecting tubes |                |                                  |

### Performance Specifications

|  |         |       |  |                                  |             |
|--|---------|-------|--|----------------------------------|-------------|
| Minimum flow rate $Q_{\min}$                     | 1       | ml/h  | Maximum gas inlet pressure                                     | <b>100</b>                       | <b>mbar</b> |
| Maximum flow rate $Q_{\max}$                     | 1       | ltr/h | Minimum gas inlet pressure                                     | 5                                | mbar        |
| Measurement accuracy, approx. <sup>1)</sup>      | $\pm 3$ | %     | Gas inlet pressure at measurement start, approx. <sup>5)</sup> | 9                                | mbar        |
| Volume of measur. chamber, approx. <sup>2)</sup> | 3       | ml    |  |                                  |             |
| Min. measuring volume (resolution) <sup>3)</sup> | 3       | ml    | Gas temperature <sup>6)</sup>                                  | +10 ~ +60                        | °C          |
| Resolution of indication <sup>4)</sup>           | 0.01    | ml    | Connection gas in/outlet                                       | Plug-in connector                |             |
| Packing liquid quantity, approx.                 | 120     | ml    | Diameter connecting tube                                       | 7 <sub>i</sub> / 11 <sub>o</sub> | mm          |

<sup>1)</sup> Because of the physical measurement principle, the measurement error is dependent on the flow rate. The **data acquisition software "Rigamo"** (accessory) provides an algorithm, which automatically recalculates the actual measurement data to the real values at the respective actual flow rate on the basis of the calibration curve. Thus, the remaining error can be reduced significantly or the flow rate range can be extended at the constant measurement error of  $\pm 3\%$ . The remaining error is better than approx.  $\pm 1\%$  across the full flow rate range.

<sup>2)</sup> = Nominal value; exact value will be determined by individual calibration

<sup>3)</sup> = Volume of measuring chamber

<sup>4)</sup> Because of calibration factor with 2 decimals

<sup>5)</sup> Higher gas inlet pressure until gas inlet channel and micro capillary in the base plate are clear of packing liquid

<sup>6)</sup> For complete MGC unit applies: With temperatures > room temperature (e.g. if placed in heating furnace) a foam formation of the packing liquid was monitored in particular cases.

### Materials

|                    |                                |
|--------------------|--------------------------------|
| Casing             | Plexiglas (PMMA)               |
| Measurement cell   | PVDF (Polyvinylidene fluoride) |
| Plug-in connectors | Brass, nickel-plated           |
| Tube adaptors      | PBT (Polybutylenterephthalat)  |

### Standard Equipment

|   |  |
|---|--|
| Electronic counter / LCD display                                      | 1 cleaning rod for micro capillary per each 1 to 5 MGC's |
| Display: 6 digits [ml] + 2 decimals                                   | Funnel for filling of liquid                             |
| Pulse Generator V6.0 as signal output (reed contact, floating output) | 200 ml packing liquid                                    |
| Twin-chamber measurement cell   | 1.5 m gas connection tubing (PVC)                        |
| 2 tube adaptors for flexible connecting tubes                         | 1 syringe for fine adjustment packing liquid level       |

### Accessories

|   |                                     |
|---|-------------------------------------|
| Data acquisition software "Rigamo" for Windows® | Packing liquid 100 / 500 / 1,000 ml |
| Gas connection tubing (PVC)                     |                                     |

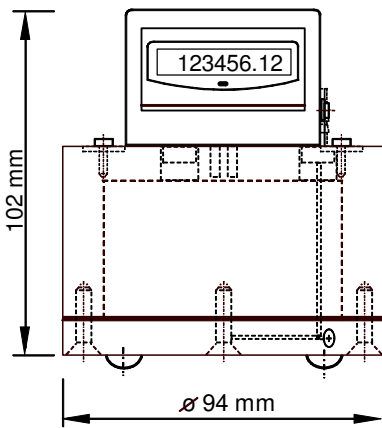

Front View

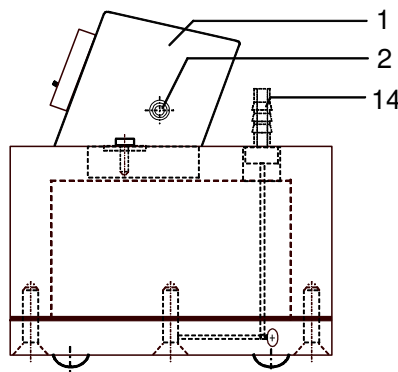

Side View

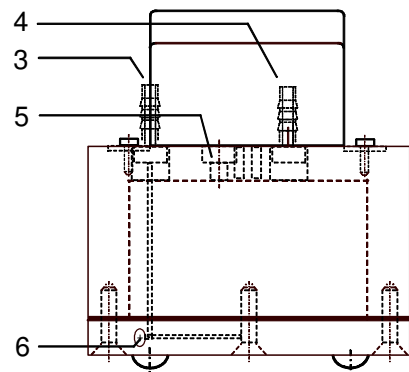

Rear View

- (1) Counter unit with LCD display
- (2) Signal Output (reed contact)
- (14) Hose barb for flexible connecting tube

- (3) Gas Inlet
- (4) Gas Outlet

- (5) Air-vent screw for filling
- (6) Inspection screw gas channel

### Performance Specifications

|  |      |       |  |                     |             |
|--|------|-------|--|---------------------|-------------|
| Minimum flow rate $Q_{\min}$                     | 1    | ml/h  | Maximum gas inlet pressure                                     | <b>100</b>          | <b>mbar</b> |
| Maximum flow rate $Q_{\max}$                     | 1    | ltr/h | Minimum gas inlet pressure                                     | 5                   | mbar        |
| Measurement accuracy, approx. <sup>1)</sup>      | ±3   | %     | Gas inlet pressure at measurement start, approx. <sup>5)</sup> | 9                   | mbar        |
| Volume of measurem. chamber, appr. <sup>2)</sup> | 3    | ml    |  |                     |             |
| Min. measuring volume (resolution) <sup>3)</sup> | 3    | ml    | Gas temperature <sup>6)</sup>                                  | +10 ~ +80           | °C          |
| Resolution of indication <sup>4)</sup>           | 0.01 | ml    | Connection gas in/outlet                                       | Compression fitting |             |
| Packing liquid quantity, approx.                 | 120  | ml    | Diameter compression fitting                                   | 8 <sub>i</sub>      | mm          |

<sup>1)</sup> Because of the physical measurement principle, the measurement error is dependent on the flow rate. The **data acquisition software "Rigamo"** (accessory) provides an algorithm, which automatically recalculates the actual measurement data to the real values at the respective actual flow rate on the basis of the calibration curve. Thus, the remaining error can be reduced significantly or the flow rate range can be extended at the constant measurement error of ±3%. The remaining error is better than approx. ±1% across the full flow rate range.

<sup>2)</sup> = Nominal value; exact value will be determined by individual calibration

<sup>3)</sup> = Volume of measuring chamber

<sup>4)</sup> Because of calibration factor with 2 decimals

<sup>5)</sup> Higher gas inlet pressure until gas inlet channel and micro capillary in the base plate are clear of packing liquid

<sup>6)</sup> For complete MGC unit applies: With temperatures > room temperature (e.g. if placed in heating furnace) a foam formation of the packing liquid was monitored in particular cases.

### Materials

|                                |                              |
|--------------------------------|------------------------------|
| Casing / connection hose barbs | PVDF (Polyvinylide fluoride) |
| Measurement cell               | PVDF (Polyvinylide fluoride) |

### Standard Equipment

|   |  |
|---|--|
| Electronic counter / LCD display                                      | 1 cleaning rod for micro capillary per each 1 to 5 MGC's               |
| Display: 6 digits [ml] + 2 decimals                                   | Funnel for filling of liquid   |
| Pulse Generator V6.0 as signal output (reed contact, floating output) | 200 ml packing liquid  |
| Twin-chamber measurement cell   | 1.5 m gas connection tubing<br>Polytetrafluoroethylene (PTFE - Teflon) |

### Accessories

|  |                                     |
|--|-------------------------------------|
| Data acquisition software "Rigamo" for Windows®                  | Packing liquid 100 / 500 / 1,000 ml |
| Gas connection tubing<br>Polytetrafluoroethylene (PTFE - Teflon) |                                     |

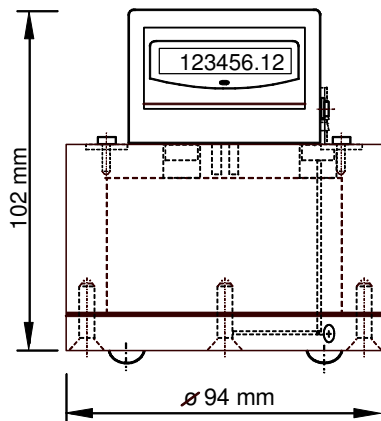

Front View

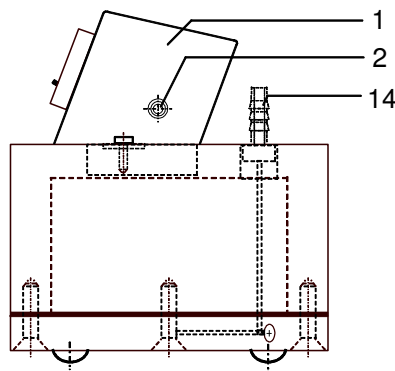

Side View

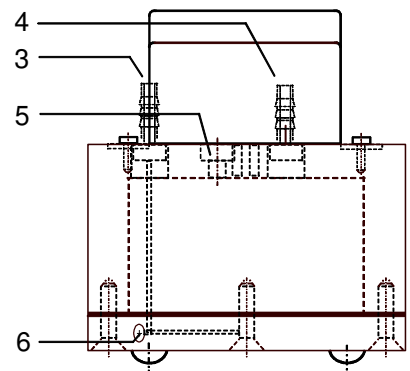

Rear View

- |   |                |                                  |
|---|----------------|----------------------------------|
| (1) Counter unit with LCD display           | (3) Gas Inlet  | (5) Air-vent screw for filling   |
| (2) Signal Output (reed contact)            | (4) Gas Outlet | (6) Inspection screw gas channel |
| (14) Hose barb for flexible connecting tube |                |                                  |

### Performance Specifications

|  |      |       |  |                |             |
|--|------|-------|--|----------------|-------------|
| Minimum flow rate $Q_{\min}$   | 1    | ml/h  | Maximum gas inlet pressure                                     | <b>100</b>     | <b>mbar</b> |
| Maximum flow rate $Q_{\max}$<br>@ measurement accuracy $\pm 3\%$ <sup>1)</sup> | 0.6  | ltr/h | Minimum gas inlet pressure                                     | 5              | mbar        |
| Maximum flow rate $Q_{\max}$<br>@ measurement accuracy $\pm 5\%$ <sup>1)</sup> | 1.0  | ltr/h | Gas inlet pressure at measurement start, approx. <sup>5)</sup> | 9              | mbar        |
| Volume of measur. chamber, appr. <sup>2)</sup>                                 | 2    | ml    |  |                |             |
| Min. measuring volume (resolution) <sup>3)</sup>                               | 2    | ml    | Gas temperature <sup>6)</sup>                                  | +10 ~ +40      | °C          |
| Resolution of indication <sup>4)</sup>   | 0.01 | ml    | Connection gas in/outlet                                       | Hose barb      |             |
| Packing liquid quantity, approx.   | 120  | ml    | Diameter hose barb   | 8 <sub>o</sub> | mm          |
|  |      |       | Diameter connecting tube                                       | 7 <sub>i</sub> | mm          |

<sup>1)</sup> Because of the physical measurement principle, the measurement error is dependent on the flow rate. The **data acquisition software "Rigamo"** (accessory) provides an algorithm, which automatically recalculates the actual measurement data to the real values at the respective actual flow rate on the basis of the calibration curve. Thus, the remaining error can be reduced significantly or the flow rate range can be extended at the constant measurement error of  $\pm 3\%$ . The remaining error is better than approx.  $\pm 1\%$  across the full flow rate range.

<sup>2)</sup> = Nominal value; exact value will be determined by individual calibration

<sup>3)</sup> = Volume of measuring chamber

<sup>4)</sup> Because of calibration factor with 2 decimals

<sup>5)</sup> Higher gas inlet pressure until gas inlet channel and micro capillary in the base plate are clear of packing liquid

<sup>6)</sup> For complete MGC unit applies: With temperatures > room temperature (e.g. if placed in heating furnace) a foam formation of the packing liquid was monitored in particular cases.

### Materials

|                                |                               |
|--------------------------------|-------------------------------|
| Casing / connection hose barbs | PVC (Polyvinyl chloride), red |
| Measurement cell               | PVC (Polyvinyl chloride), red |

### Standard Equipment

|  |  |
|--|--|
| Electronic counter / LCD display   | 1 cleaning rod for micro capillary per each 1 to 5 MGC's |
| Display: 6 digits [ml] + 2 decimals                                      | Funnel for filling of liquid                             |
| Pulse Generator V6.0 as signal output<br>(reed contact, floating output) | 200 ml packing liquid                                    |
| Twin-chamber measurement cell  | 1.5 m gas connection tubing (PVC)                        |

### Accessories

|   |                                     |
|---|-------------------------------------|
| Data acquisition software "Rigamo" for Windows® | Packing liquid 100 / 500 / 1,000 ml |
| Gas connection tubing (PVC)                     |                                     |

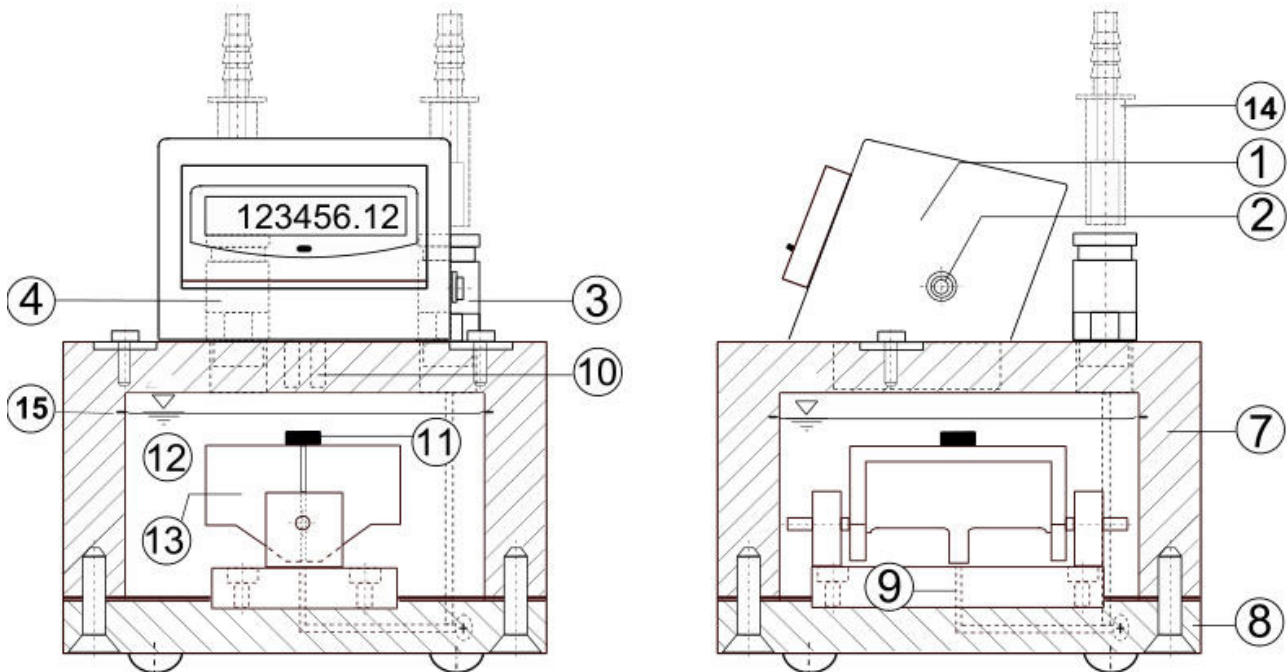

MGC-1 (Graphic shows PMMA version)

- |  |   |
|--|---|
| (1) Counter unit including LCD display   | (10) Two Reed Contacts                                  |
| (2) Signal output socket of reed contact | (11) Permanent magnet                                   |
| (3) Gas inlet connector                  | (12) Packing liquid                                     |
| (4) Gas outlet connector                 | (13) Measurement cell (tilting body) with twin-chambers |
| (7) Casing                               | (14) Tube adaptors for flexible connecting tubes        |
| (8) Casing base plate                    | (15) Scratch mark (filling level packing liquid)        |
| (9) Micro capillary tube                 |   |

## 2. Initial Operation

### 2.1. Handling after receipt

- a) read this operation instructions carefully to guarantee a long and trouble-free operation.
- b) Unpack the MilliGascounter carefully. The box contains:
  - 1 MilliGascounter
  - 2 tube adaptors for flexible connecting tubes
  - 1 bottle of packing liquid (200ml)
  - 1.5 m tubing
  - 1 funnel for filling of packing liquid
  - 1 cleaning tool (PMMA rod with inserted wire) per each 1 to 5 MGC's
  - 1 syringe (fine adjustment of the packing liquid level) per each 1 to 5 MGC's

### 2.2. Installation

- a) The MilliGascounter should be installed on a horizontal, solid and vibration-free base.

- b) If the gas to be measured contains water vapour or an other condensable gas, it is necessary to make sure that the gas does not condense inside the MilliGascounter. This can be achieved through *cooling* the gas to room temperature before-hand or through using a *condensation trap*. The easiest way to cool the gas is to use proportionately longer feeder tubing or a metal pipe (e.g. 20 cm long); if necessary, the feeder tubing can be passed through a water bath.

If condensation cannot be avoided, the MilliGascounter should be installed in such a way, that the condensation present in the feeder tubing cannot flow into it<sup>7</sup>. At the same time such a condensation trap also prevents the reverse, i.e. it prevents the packing liquid from flowing backwards into the gas supply line or to the gas source (fermentation tank). This can occur as a result of a drop in temperature within the gas source/gas supply line system (fermentation equipment) creating an under-pressure. Simple condensation traps such as these can be supplied upon request. If condensation gets into the MilliGascounter nevertheless, it will collect at the bottom of the packing liquid casing and can be siphoned off with a pipette.

### 2.3. Filling

The special packing liquid delivered with the MilliGascounter should be used for filling **only**, as the calibration is only valid with this packing liquid. (If a different liquid is used, unavoidable measurement errors will occur due to the different liquid properties like viscosity or surface tension.)

The packing liquid is physiologically safe. If clothing is stained, it can be treated in the same way as oil stains (the packing liquid is an oily polymer).

#### 2.3.1. PMMA Version (Transparent Casing)

For filling of the liquid the supplied funnel should be placed into the gas outlet nozzle (4). After removing of the air-vent screw (5) the liquid can be poured into the casing. The MilliGascounter is properly filled (approximately 120 ml are needed), when the liquid level is at the same level as the marked (scratched) line (15) inside of the MGC (high-lighted red line).

For fine adjustment of the packing liquid level (setting higher or lower) we recommend to use a syringe which is part of delivery.

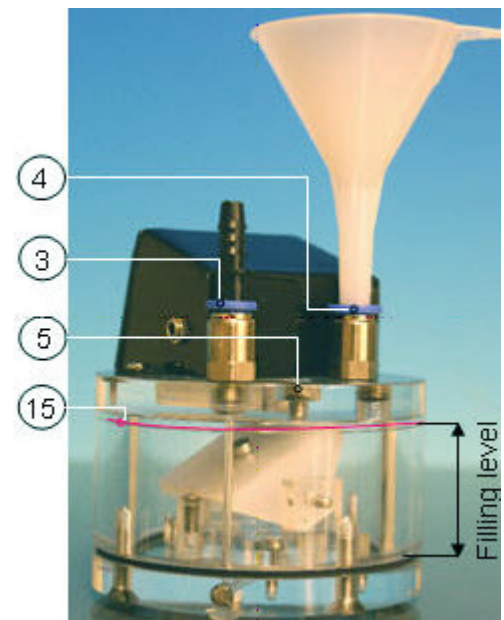

<sup>7</sup> We recommend using condensation traps when the MilliGascounter is connected to a fermentation tank, and in particular with thermophilic fermentation processes. A large quantity of water vapour can develop particularly in those cases.

### 2.3.2. PVDF and PVC Version

Scope of delivery<sup>8</sup>:



Open the air-vent screw:



Put the funnel into gas outlet nozzle



Place the level onto the casing and align horizontally:

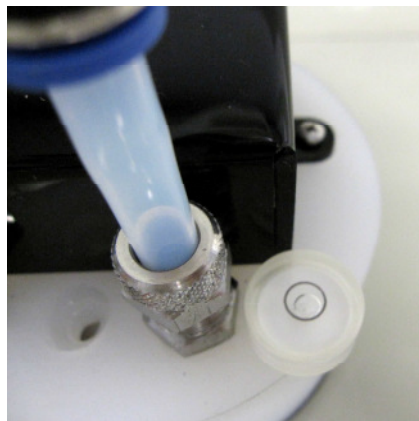

Pour the liquid into the MGC:

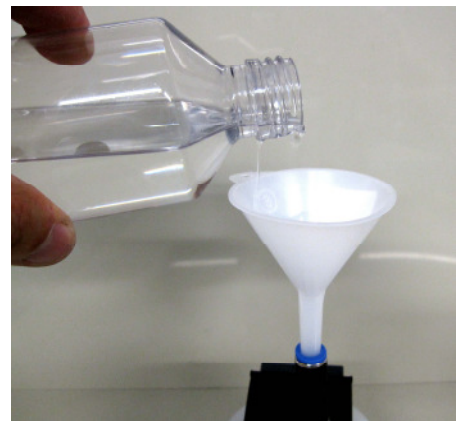

Correct liquid level:

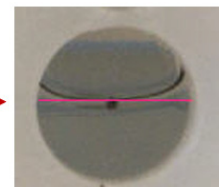
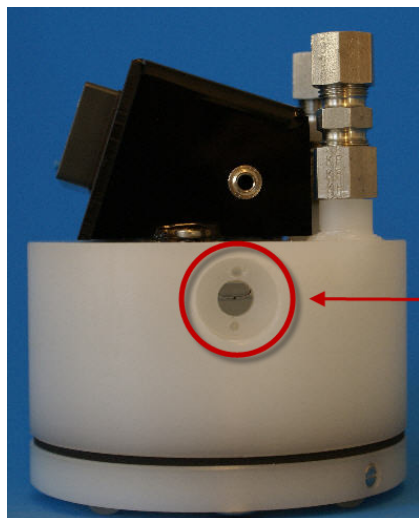

<sup>8</sup> Scope of delivery: MGC / packing liquid / cleaning rod / tubing / funnel / funnel adaptor / level / syringe / 2 compression fittings (PVDF version only)

For fine adjustment of the packing liquid level (setting higher or lower) we recommend to use a syringe which is part of delivery:

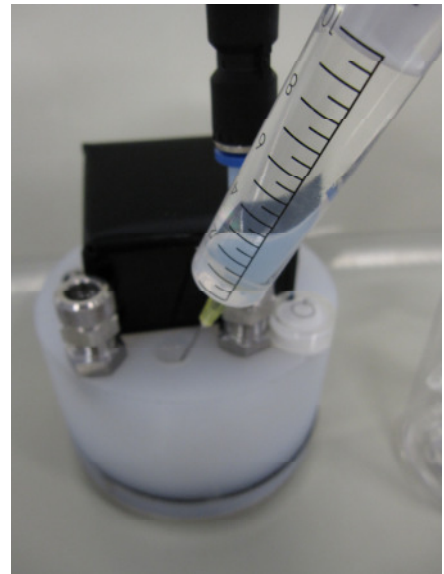

## 2.4. Connection of Tubing

Flexible tubing to and from the MilliGascounter can be connected to the tube adaptors which belong to the scope of delivery. These adaptors are then plugged into the gas inlet/outlet connectors (3). An O-ring inside of the connector provides a gas tight connection; recommended dimensions of flexible tubing<sup>9</sup>: Inside diameter 7 mm, outside diameter 11 mm.

Rigid tubing (such as polyamide tubing) to and from the MilliGascounter can be connected to the gas inlet/outlet connectors (3) without using the above-mentioned tube adaptors; recommended dimensions of rigid tubing: Inside diameter 6 mm, outside diameter 8 mm.

Please use gas-tight tubing for connection to the MilliGascounter. Silicone tubing is therefore not suitable and simple rubber tubing is only conditionally suitable.

## 3. Measurement

### 3.1. Measurement principle

The gas to be measured flows in via the gas inlet nozzle (3), through the micro capillary tube (9) located at the base of the MilliGascounter and up into the liquid casing which is filled with a packing liquid (12).

The gas rises as small gas bubbles through the packing liquid, up and into the measurement cell (13). The measurement cell consists of two measuring chambers, which are filled alternately by the rising gas bubbles. When a measuring chamber is filled, the buoyancy of the filled chamber causes the measurement cell to abruptly tip over into such a position that the second measuring chamber begins to fill and the first empties.

The measurement of gas volume therefore occurs in discrete steps by counting the tilts of the measurement cell (13) with a resolution of approximately 3 ml (= content of one meas-

---

<sup>9</sup> 1.5 m of tubing is included as standard equipment and is therefore delivered with the unit.

uring chamber, please refer to Point 3.2). This “residual error” (= max. 3 ml) caused by the resolution should be taken into account when estimating/calculating the total measurement error.

The tilting procedure of the measurement cell creates by the permanent magnet (11) on top of the cell and one of the two magnetic sensors (reed contacts) (11) a pulse which is registered by the counter unit (1).

The switching pulses of a second reed contact can be obtained via the signal output socket (2). (please refer to Point 4.3).

The measured gas escapes through the gas outlet nozzle (4).

### **3.2. Calibration / Measurement Error**

#### **3.2.1. Static Correction of Manufacturing Tolerances**

Because of manufacturing tolerances, the exact volume of a measurement cell is generally  $\neq$  3 ml. The deviation (= measurement error) from the norm-value of 3 ml is determined at the time of calibration. This calibration factor

- Is determined at the standard flow rate of 600 ml/h,
- is noted in the calibration protocol,
- is programmed into the counter unit. This means that the measured volume (= number of tilts of the measuring cells) is multiplied by the programmed Calibration Factor and the result is displayed.

#### **3.2.2. Dynamic Correction of the Measurement Error**

Because of the physical measurement principal, the measurement error is dependent on the flow rate. The error is approx. +3% at min. flow rate and -3% at max. flow rate.

A data acquisition software “Rigamo” is available as accessory which provides – among other features– an automatic correction of the dynamic (flow rate dependent) measurement error. The algorithm of this software automatically recalculates the actual measurement data of gas volume and flow rate to the real flow rate on the basis of the calibration curve. **The remaining error is better than approximately  $\pm 1\%$  across the full flow rate range.**

### **3.3. Effect of Dead Space Volume**

The dead space volume is defined as the volume of the total gas pipe line system between the gas source and the MilliGascounter (for fermentation tests: including the volume of the fermentation vessel above the substrate).

If the measurement of the gas volume starts at ambient pressure (gauge pressure in the pipe system = 0), the generated gas volume causes an increase of the pressure in the pipe system only at first. Only after exceeding the minimum gas inlet pressure of 5 mbar the measuring of the gas volume by the MilliGascounter starts.

Due to the design of the MilliGascounter an overpressure of 5 mbar will remain in the dead space volume at the end of the test. The deficit volume caused by this effect has to be added to the measured volume and it is calculated as follows:

$$V_D = V_{DS} \times \frac{P_N + P_{DS}}{P_N}$$

whereby

|          |   |   |                  |
|----------|---|---|------------------|
| $V_D$    | = | Deficit volume                          |                  |
| $V_{DS}$ | = | Dead space volume                       |                  |
| $P_N$    | = | Norm-Pressure                           | = 1013.25 [mbar] |
| $P_{DS}$ | = | Remaining pressure in dead space volume | = 5 [mbar]       |

### 3.4. Influence of Particles (Dirt & Dust) in the Gas Flow

If the gas flow in the incoming tubes or in the micro capillary tube is obstructed by particles or liquid, the calibration factor will be affected. Therefore, dust particles have to be absorbed by a suitable filter and the inner surface of the tubes from the gas source must be dry.

### 3.5. Effect of Temperature

Because of the extreme resolution of the MilliGascounter in the milli-liter range, "volume flows" can also be registered as a consequence of changes in temperature. A temperature rise [or decrease] at the gas source or respectively in the supply system causes an expansion [or contraction] of the gas present in the system proportional to its volume. Whereas an expansion of the gas generates a „virtual“ gas flow (with an corresponding display at the counter unit), a contraction causes an under-pressure in the supply system. This under-pressure enables packing liquid to flow through the micro capillary tube into the gas feeder tubing. Packing liquid in the gas feeder tubing causes

- ⇒ an increased admission pressure,
- ⇒ a time delay until the first display on the counter unit (until the micro capillary tubing is once again free of packing liquid),
- ⇒ erroneous measurement deviations.

No actual measurement should therefore be started until the temperature of the total system has been adjusted<sup>10</sup>. An expansion of the gas during adjustment of the temperature and the subsequent build-up of an overpressure can simultaneously be used as an operational check of the MilliGascounter (description of the Reset Button, please refer to Point 4.2).

The room temperature should remain approximately the same during the whole of the measurement period. (Please mind a temperature decrease during the night and over the weekend.) Otherwise the temperature has to be monitored so that an integrating correction of the measurement values can be made (please refer also to: „Temperature- and Pressure corrections“). Another alternative is the installation of the MilliGascounter, gas feeder tubing and gas source in a temperature-controlled cupboard.

### 3.6. Effect of System Gas Pressure

A rise [decrease] in pressure at the gas source or respectively in the gas supply system causes an expansion [contraction] of the gas present, proportional to its volume. The same therefore applies to air pressure as was mentioned in the previous Section on the Effect of Temperature.

<sup>10</sup>With fermentation tests: After equalization with the fermentation temperature.

### 3.7. Effect of Water Vapour Partial Pressure<sup>11</sup>

If the measurement result has to be corrected for the volumetric share of water vapour, the values in the following table 1, which take the temperature into account, can be used in the equation listed under point 3.8.

| Temp.<br>°C | Water vapour<br>partial pressure<br>mbar (psi) | Temp.<br>°C | Water vapour<br>partial pressure<br>mbar (psi) | Temp.<br>°C | Water vapour<br>partial pressure<br>mbar (psi) |
|-------------|--|-------------|--|-------------|--|
| 15          | 17.0 (0.246)                                   | 20          | 23.4 (0.339)                                   | 25          | 31.7 (0.459)                                   |
| 16          | 18.1 (0.262)                                   | 21          | 24.9 (0.361)                                   | 30          | 42.6 (0.617)                                   |
| 17          | 19.4 (0.281)                                   | 22          | 26.4 (.0383)                                   | 35          | 56.4 (0.817)                                   |
| 18          | 20.6 (0.299)                                   | 23          | 28.1 (0.407)                                   | 40          | 73.9 (1.071)                                   |
| 19          | 22.0 (0.319)                                   | 24          | 29.9 (0.433)                                   | 45          | 95.9 (1.390)                                   |

Table 1: Values of water vapour partial pressure

### 3.8. Temperature and Pressure Corrections

The MilliGascounter is a volumetric gas meter and therefore measures gas volume in the actual operating state existing at the time of measurement. The gas volume is dependent on gas temperature, air pressure and water vapour partial pressure (for water vapour partial pressure refer to footnote "10"). These measurable variables are therefore needed to recalculate to norm conditions. The gas temperature is to be measured at the gas **outlet**.

According to the general gas laws the following equation is used for temperature and pressure corrections:

$$V_N = V_i \times \frac{P_a - P_v + P_L}{P_N} \times \frac{T_N}{T_a}$$

| whereby | Symbol         | Description   | Unit | Value     | Unit            |
|---------|----------------|---|------|-----------|-----------------|
|         | V <sub>N</sub> | Norm-Volume   | in   |           | [ltr]           |
|         | V <sub>i</sub> | Indicated (displayed) Volume                                | in   |           | [ltr]           |
|         | P <sub>a</sub> | Actual Air Pressure   | in   |           | [mbar-absolute] |
|         | P <sub>v</sub> | Water vapour partial pressure                               | in   |           | [mbar]          |
|         | P <sub>L</sub> | Pressure of the Liquid Column above the Measurement Chamber | = 1  |           | [mbar]          |
|         | P <sub>N</sub> | Norm-Pressure   |      | = 1013.25 | [mbar]          |
|         | T <sub>N</sub> | Norm-Temperature  |      | = 273.15  | [Kelvin]        |
|         | T <sub>a</sub> | Actual Temperature  | in   |           | [Kelvin]        |

If the exact air pressure is not known, the norm-pressure can in that case be used. Air pressure swings of 980 - 1050hPa create errors in the range of -3.3% to +3.7%.

<sup>11</sup>The information in this point 3.7 is valid only for gases which contain water vapour **and** if the volume of the water vapour **must be** mathematically eliminated from the measurement result. If the water vapour is a „natural“ element of the gas and its volume should therefore be taken into account, then no (partial-)pressure correction should be carried out. In that case, p<sub>v</sub> = 0 must be used in the equation listed under point 3.8.

### 3.9. Special Features with Fermentation Tests

- In incubators without compulsory ventilation, uneven temperature distribution can cause under-pressure in the reaction vessels.
- The free volume in the fermentation tank and in the feeder tubing to the MilliGascounter should not be smaller than 0.5 ltr. This volume acts as a buffer volume with both eruptively running fermentation processes and reduction of temperature to prevent the generation of under-pressure. Because of this, only tanks which have a free volume of at least 0.5 liters above the test material should be used.
- To determine the total gas production as accurately as possible, it is advisable to leaven the released CO<sub>2</sub> in the fermentation tank to pH 1-2 after the fermentation test has ended. However, this can lead to foam formation and wetting of the tubing.
- The MilliGascounter was calibrated at room temperature (21°C). If the in-house standard temperature is 21 °C as well (instead of the international standard of 0 °C / 273.15 K), the temperature correction is not necessary when the gas is cooled down to 21 °C. With a fermentation temperature of 37°C this is obtained when using a connecting tubing with a length of 1.5 m.
- If the biogas contains high amounts of ammonium and H<sub>2</sub>S the possibility increases, that the micro capillary of the gas inlet pipe plugs. In such a case it is recommended to install an absorber flask in the gas tubing to the MilliGascounter. This absorber flask can content ferric iron pebbles (ferrous oxide). Hydrogen sulphide will be linked to the ferric iron pebbles. But such an absorber flask can also content that kind of charcoal, which is used also e.g. in kitchen hoods. If the medium in the absorber flask is used up (recognised by the smell or if there is no cleaning effect any more) the medium has to be replaced.
- Experiments to determine the methanogenic potential of organic substances in the laboratory of Prof. Dr. Paul Scherer<sup>12</sup> (University of Applied Sciences Hamburg, Paul.Scherer@rzbd.haw-hamburg.de) have shown that the dry matter content of the seed sludge has not only an influence on the velocity of the gas production, but also on the total amount of produced gas. Of course in all cases parallel to the gas production of a test substance a reference without added organics was subtracted. Based on these findings it is recommended to use in such experiments at least 3% dry matter content of a seed sludge. It is important to homogenize the sludge by a mixer before use. It is also of importance that thickened sewage sludge often contains small amounts of polymers to support the coagulation. But added polymers often contain substantial amounts of biodegradable alkanes to facilitate the addition. These additives increase the background production of biogas during a test period. If the background production of biogas is too high this could complicate the calculation of the gas production of the test substance.

But if the gas production of the seed sludge is too low then in some situations it can occur that the pressure in the test flasks drops down below the atmospheric pressure. According to the principle of connected tubes this can lead to a flow of oily packing liq-

---

<sup>12</sup>Scherer, P.A. (2001) Influence of high solid content on anaerobic degradation tests measured online by a MilliGascounter® station for biogas. In: Proceedings of the 9<sup>th</sup> World Congress on "Anaerobic Digestion 2001" (L. van Velsen, W. Verstraete, Eds.), Antwerpen.

uid into the test trial vessel. In such cases it is recommended to increase the background gas production by the addition of cellulose powder (e.g., Avicel). Also the test approach should be started at room temperature so that the temperature in the incubators (mostly 35-37 °C) increases smoothly generating thereby a small overpressure.

## 4. Counter unit

### 4.1. Display

Gas volume is displayed in milli-liters (6 digits) with a resolution of 0.01 ml. The calibration factor resulting from the calibration is programmed into the counter unit. This means that the measured volume (= number of tilts of the measuring cells) is multiplied by the programmed calibration factor and the result is displayed.

### 4.2. Reset Button

The blue reset button is located under the digital display. A press of the reset button erases the measurement value memory and sets the display back to zero. The calibration factor remains preserved in the counter unit.

### 4.3. Signal Output

#### 4.3.1. Reed Contact

- **Function:**

The measurement of the flowing gas volume occurs by counting the number of tilts of the measurement cell (13) by means of a permanent magnet (11) and two magnetic sensors (reed contacts). The magnet is located at the top of the measurement cell, the reed contacts are located within the cover on top of the casing.

The tilting procedure of the measurement cell closes the two reed contacts. The first reed contact initiates a counter pulse at the counter mechanism (1). Additionally, the second reed contact works as a pulse generator (V6.0) and can be used as a signal output from the MilliGascounter to an external data acquisition system. Please note that **display** shows the **true gas volume** (i.e. the measured volume multiplied by the calibration volume) whereas the **pulses** counted at the **output socket** are equivalent to the number of tilts and hereby equal to the **uncorrected (not calibrated) gas volume**.

The reed contact of the signal output works as a potential-free closing contact.

- **Electrical Data:**

|                                  |     |      |
|----------------------------------|-----|------|
| Max. switching power             | 10  | Watt |
| Max. switching current           | 0.5 | A/DC |
| Max. switching voltage           | 100 | V/DC |
| Switch-/closing time, approx.    | 0.1 | sec  |
| Rebound time                     | < 1 | msec |
| Max. switched contact resistance | 150 | mOhm |

### 4.3.2. Output Socket

The switching pulses of the reed contact can be obtained at the output socket (2).

**Attention:** The switch pulses of the reed contact are equal to the number of tilts of the measurement cell. The pulses therefore represent the uncorrected (not calibrated) measured gas volume. The gas volume obtained via the signal output socket must therefore be multiplied by the calibration factor to get the true gas volume.

The output socket is a standard 3.5 mm stereo socket, into which a compatible jack plug can be inserted (identical to a jack plug of walkman cassette players).

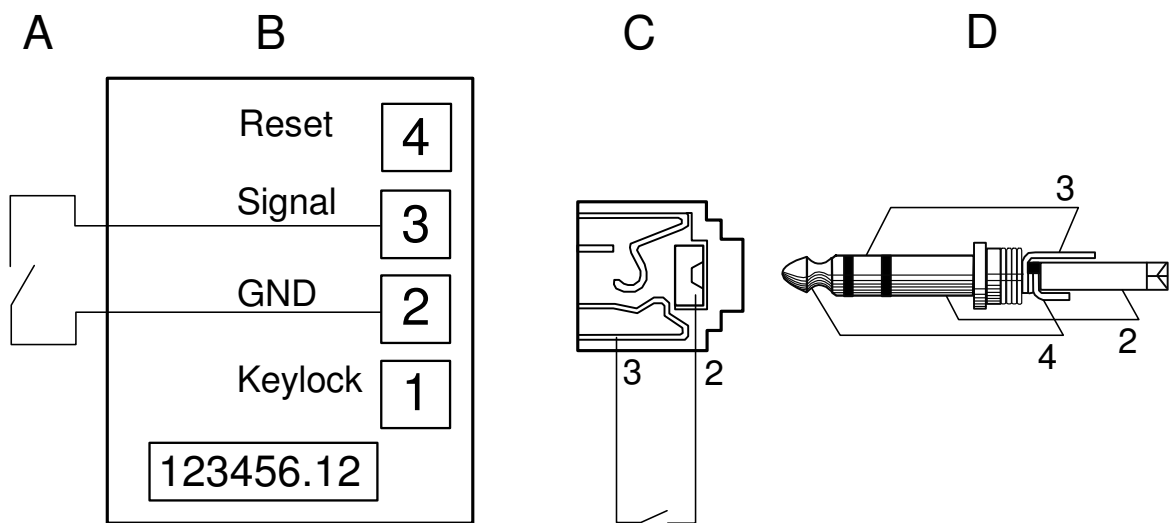

Legend:

| Part | Function   |
|------|--|
| A    | Reed Contact no. 1 for counter                         |
| B    | Counter and LCD display                                |
| C    | Reed Contact no. 2 for output signal and Output Socket |
| D    | Jack plug (3.5 mm stereo socket)                       |

| Pin / Contact of Jack Plug | Function |
|----------------------------|----------|
| 2                          | Ground   |
| 3                          | Signal   |
| 4                          | Not used |

## 5. Maintenance

### 5.1. Checking the Packing Liquid Level

The rate of evaporation of the packing liquid in the MilliGascounter is very slow but dependant upon the gas flow rate as well as the operating temperature. Also the diameter of the gas outlet nozzle (4) contributes to it. Therefore the evaporation can be diminished even more by closing the outlet with a stopper and piercing it with a syringe needle. To ensure stable measurement accuracy therefore, the packing liquid level must be checked from time to time. (Regarding the correct level please refer to par. 2.3 "Filling).

## 5.2. Exchange of Packing Liquid

An exchange of the packing liquid

- is **necessary** when particles or substances of the gas, which are imposed to the liquid, create a bubbling or foaming of the liquid,
- is **recommended** when a visible large quantity of particles are floating in the liquid.

## 5.3. Cleaning the Micro Capillary Tube

The free cross-section of the micro capillary outlet (9) on the bottom of the liquid container has a substantial influence on the measurement accuracy. A narrowed gas outlet primarily influences the gas pressure, which can then also increase to over 30 mbar in the gas supply lines and cause a pulsating gas flow. This leads to erroneous measurement deviations. The micro capillary tubing should therefore be cleaned occasionally.

- To do this, empty the MilliGascounter by either pouring out the packing liquid through the gas outlet nozzle (4) or by sucking it out through this nozzle with a pipette.
- Remove the 4 closing screws underneath the casing base plate.
- Remove the 4 screws of the fixture of the measurement cell support (bearing block) which is located at the base plate.
- The micro capillary should only be cleaned with the cleaning rod containing a fine wire delivered for this purpose with the MilliGascounter. A wire with a smaller diameter would not have the desired cleaning effect, a larger diameter could damage the micro capillary and consequently lead to an alteration in the calibration and **measurement error**.
- Re-assemble the fixture of the measurement cell to its original position.
- Re-assemble the casing base plate to the casing. Please mind the proper position of the sealing ring. The tightening sequence of the 4 base plate screws should be such that one screw pair positioned at opposite sides of the casing base plate is tightened first followed by the second screw pair (not all screws one after the other in circumferential direction). The **torque for tightening the screws** must not exceed **3 Nm** ("hand-tight") to avoid a damage of the plastic threads.
- Fill the MilliGascounter with liquid according to par. 2.3 "Filling".

## 5.4. Counter Unit Battery Exchange

The counter unit is equipped with a lithium battery (2 V) with a working life of 4 to 5 years (no responsibility is taken for the correctness of this information<sup>13</sup>). Unfortunately, the battery cannot be exchanged easily because it is welded to its support. Furthermore, the programmed calibration factor is erased when the battery is removed. Special hardware and software equipment is required to reprogram the calibration factor, which means that the reprogramming can only be done by the manufacturer.

Therefore, the MilliGascounter has to be sent back to the manufacturer for a battery change.

---

<sup>13</sup> Besides tolerances during manufacturing the storage and working temperature of the battery / MilliGascounter affects the working life.

### **5.5. Disassembly / Exchange of the Measurement Cell**

If it should become necessary to exchange the measurement cell, it is recommended to return the whole unit to the manufacturer. If this is not possible or if it is uneconomical, the measurement cell (including the cell bearing block) can be exchanged as follows:

- Follow the instructions according par. 5.2 (a) to (c)
- After having received the replacement cell (including the cell bearing block), follow the instructions according par. 5.2 (d) to (g) for re-assembling the cell.

After the assembly is completed, it is recommended to perform the following function tests:

- Free swinging: Hold the MilliGascounter upside down and swing the whole unit. The measurement cell should swing free and easily.
- Gas tightness of the MilliGascounter: Close the gas outlet nozzle (4) by inserting a sealed tube. Apply a gas pressure of approx. 10 to 20 mbars to the gas inlet and monitor the pressure indication (manometer). The pressure should remain constant.

### **5.6. Long-term Storage**

The permanent magnet on top of the measurement cell is not resistant to corrosion. When not needed, store the MilliGascounter therefore either completely dry and airtight (both connection nozzles closed) or filled with packing liquid.